

2Fxx/3Fxx

PN16-25-40 Flanged Globe Valves and PN 40 Extended Neck Valves

APPLICATION AND USE

2Fxx / 3Fxx series valves are used to control fluids belonging to the group 1 or 2 according to article 13 of 2014/68/UE directive (PED) in air-conditioning, thermoventilation and heating plants and in industrial processes; therefore, they cannot be employed as safety valves.

INSTALLATION

Hydraulic Connections

Follow the fluid directions as shown in the diagram below.

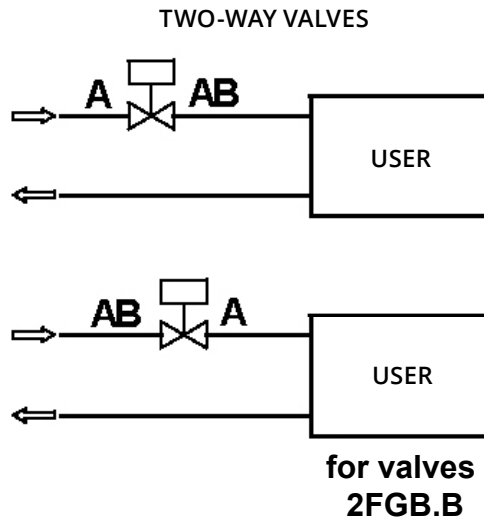

Fig. 1 Variable flow control to the user

It is advisable to install two-way valves on the return leg (excluding steam plants) since the lower temperature of the fluid allows a longer life of the gaskets.

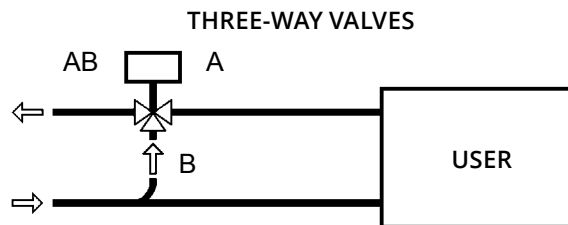

Fig. 2 Variable flow mixing to the user

Three-way valves must be used as mixers, two inlets A and B and one outlet AB, and not as diverting valves with one inlet AB and two outlets A and B.

The use of diverting valves can be necessary only in open circuit plants. In such cases our mixing valves can be used taking into account that the maximum recommended differential pressure must be reduced to one third of the specified value, see relevant data sheet.

ASSEMBLING

Before installing the valve, make sure the pipes are clean and free from weld slag in order not to damage the internal parts of the valve itself. The pipes must be perfectly aligned with the valve body and not be subjected to vibrations.

For applications with fluids above 200°C (steam, overheated water, diathermic oil), install expansion joints to avoid the expansion of the pipes to cause undue stress on the valve body.

The valve can be mounted in any position within 180°. In case of MVH actuator, always mount it with the shaft in horizontal position (see fig. 3).

During the actuator position adjustment, do not unscrew the stroke adjustment nut.

The performances stated in this sheet can be modified without any prior notice.

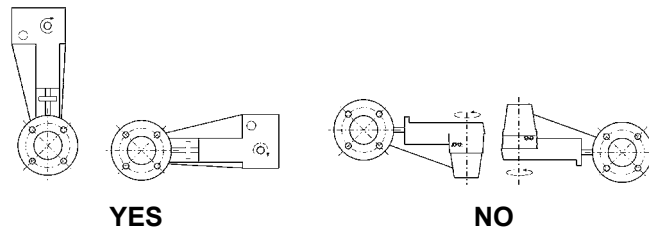

Fig. 3

The valve must be mounted horizontally in all applications where the high temperature of the fluid, contributes, together with room temperature, to create around the actuator an ambient at a temperature higher than 50°C, the maximum allowable value for its regular operation.

The actuators must not be installed in explosive environments and must not be subjected to steam jets or dripping water.

Leave sufficient room over the actuator, at least 10-15cm., to allow the actuator disassembling from the valve body for eventual maintenance.

START-UP

Before the valve start-up, check:

- **FLOW DIRECTION**
It must correspond to the indications printed on the valve body and shown in Fig. 1 and 2.
- **VALVE OPENING AND CLOSING**
This must comply with the plant specification, keep in mind that:

Two-way valves (2FGA - 2FGA.B - 2FAA - 2FAA.B - 2FAA.P - 2FAA.T)

Stem down = fluid intercepted
Stem up = fluid passing

Two-way valves (all other models)

Stem down = fluid passing
Stem up = fluid intercepted

Three-way valve

Stem down = fluid flows through A-AB
fluid intercepted through B-AB
Stem up = fluid intercepted through A-AB
fluid flows through B-AB

- **OPERATING CONDITIONS**
Temperature, nominal pressure and differential pressure on the valve must be within the values specified for each valve model on the relevant data sheets.
- **PIPE FLUSHING**
An anomalous valve flow action is caused, in almost all cases, by weld slag or foreign bodies entrapped between the valve seat and the plug, often causing damages.
To prevent such inconveniences, it is advisable to use filters upstream of the valve.
Moreover, the pipelines must be thoroughly washed by positioning the valve stem at half stroke; this operation must be performed before start-up and after a prolonged shutdown of the system.

MAINTENANCE

1. Stem packing tight check

Mod. 2FSA - 2FSA.B - 2FAA - 2FAA.B - 2FAA.P - 2FAA.T - 2FGA - 2FGA.B - 3FSA - 3FSA.S - 3FAA - 3FAA.P - 3FAA.T

The valves require periodic maintenance; an annual inspection is advised. Following the hydraulic installation it is necessary to check the tight of the stem packing placed on the bonnet, both in cases of low and high temperatures.

Valves have a stem packing with Teflon rings or, in case of extended neck valves for high temperatures, with packing. In case of leakage, it is necessary to tighten the gland nut so until leakage ceases. Do not overtighten since this may cause the stem blocking.

Mod. 2FGB - 2FGB.B - 3FGB

Valves are equipped with a stuffing box sealed by a double O-ring and, therefore, they do not require any particular maintenance. In case of irregular leakage, O-Rings and stem packing have to be replaced.

2. Valve stem lubrication

For extended neck valves equipped with a forced lubrication device (mod. 2FAA.P - 3FAA.P), periodically rotate the greaser nipples in order to grant an adequate stem lubrication.

Inject the grease with the pressure screw at its stroke end, by completely unscrewing the greaser nipple.

Fill with silicon grease, then re-tighten the screw a few turns. This operation must be carried out with the plant out-of-service and with the valve plug in closed position.

MAX. OPERATING PRESSURE (kPa) ACCORDING TO TEMPERATURE (UNI1284)

Fluid Temp. [°C]	2FGB/3FGB 2FGB.B PS89	2FGA 2FGA.B	2FAA 2FAA.B 3FAA	2FAAP 3FAAP*	2FAAT 3FAAT*	2FSA/3FSA 2FSA.B	3FSAS (bellows tight)
	PN16	PN16	PN40	PN40	PN40	PN25	PN25
-20 to -10							
-10 to 120	1600	1600	4000	4000	4000	2500	500
120 to 150	1400	1400	3700	3700	3700	2300	
150 to 200		1300	3200	3200	3200	2000	
200 to 230			3000	3000	3000	1900	
230 to 250				2800			
250 to 300				2400			
300 to 350				2200			

* Models 3FAA125P and 3FAA125T are PN25.