

## IQView../SM Surface Mount Touch Screen Display

**Important: Retain these instructions**

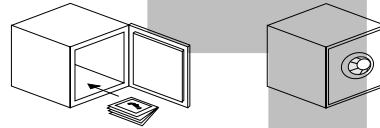

### CONTENTS

1.1 Unpacking	1 - 1	2.1 Installation Instructions - Mounting (continued)	2 - 1
1.2 Storage	1 - 1	2.2 Installation Instructions - Configuration	2 - 1
1.3 Installation Instructions - Mounting	1 - 1	3.1 Installation Instructions - Configuration	3 - 1
		3.2 Disposal	3 - 3
		3.3 End User Licence Agreement	3 - 4

### SHEET 1: Installation Instructions

#### 1.1 Unpacking

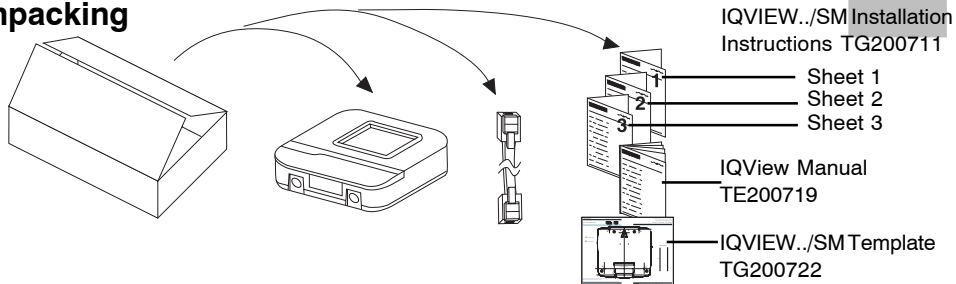

#### 1.2 Storing

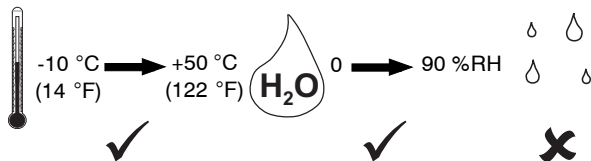

It is recommended that the installation should comply with the HSE Memorandum of Guidance on Electricity at Work Regulations 1989. For USA install equipment in accordance with National Electric Code

**WARNING**  
Other than removing front covers (see step 4), do not attempt to open the unit. Failure to comply may cause damage to the unit.

#### 1.3 Installation - Mounting

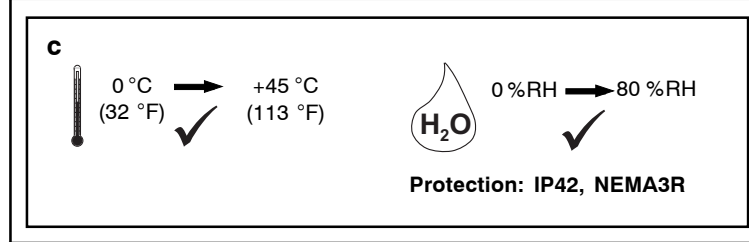
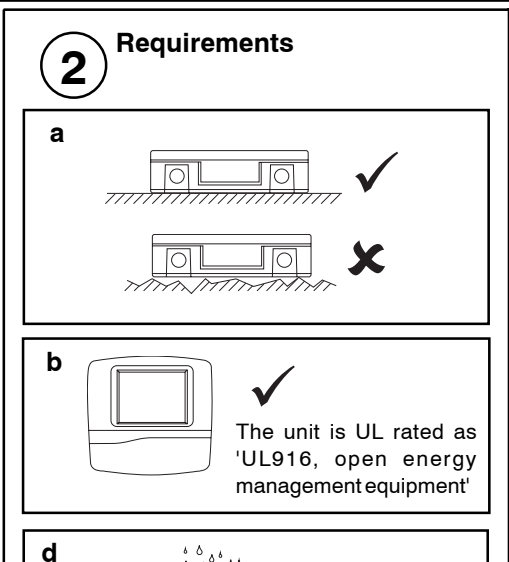
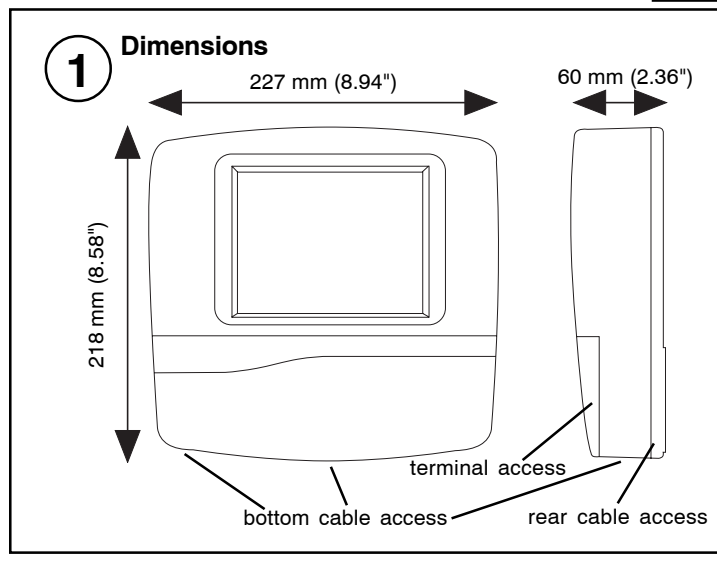

1.3 Installation - Mounting (continued)

**3** Care of Touch Screen

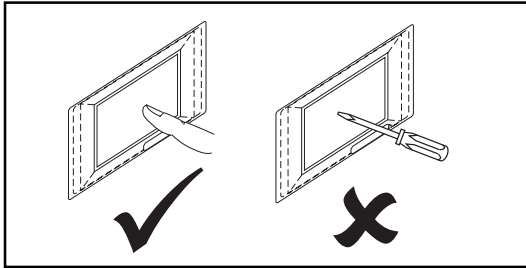

**Clean Screen**

Remove dust and grease regularly by wiping gently with a soft cloth such as that used for spectacles

**4** Remove Covers

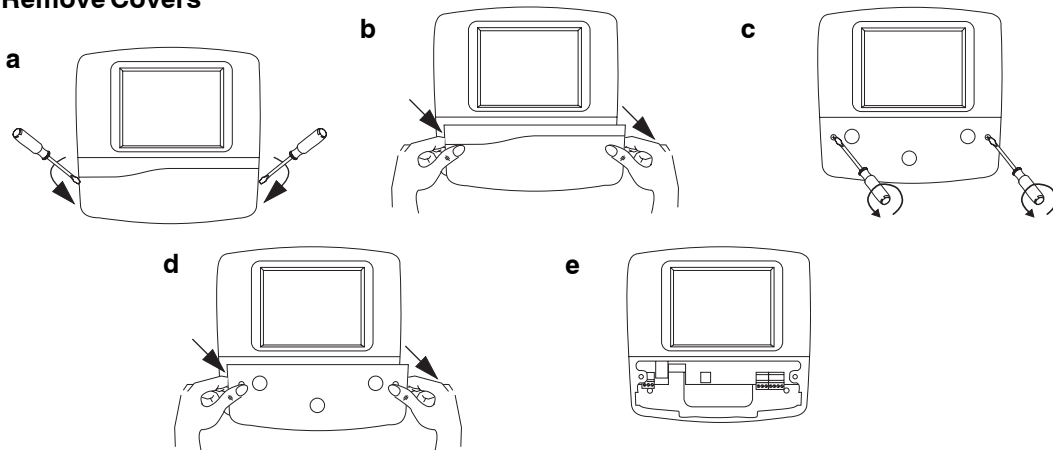

**5** Mount Unit

either by using 3 screws (e.g. for mounting on wall)

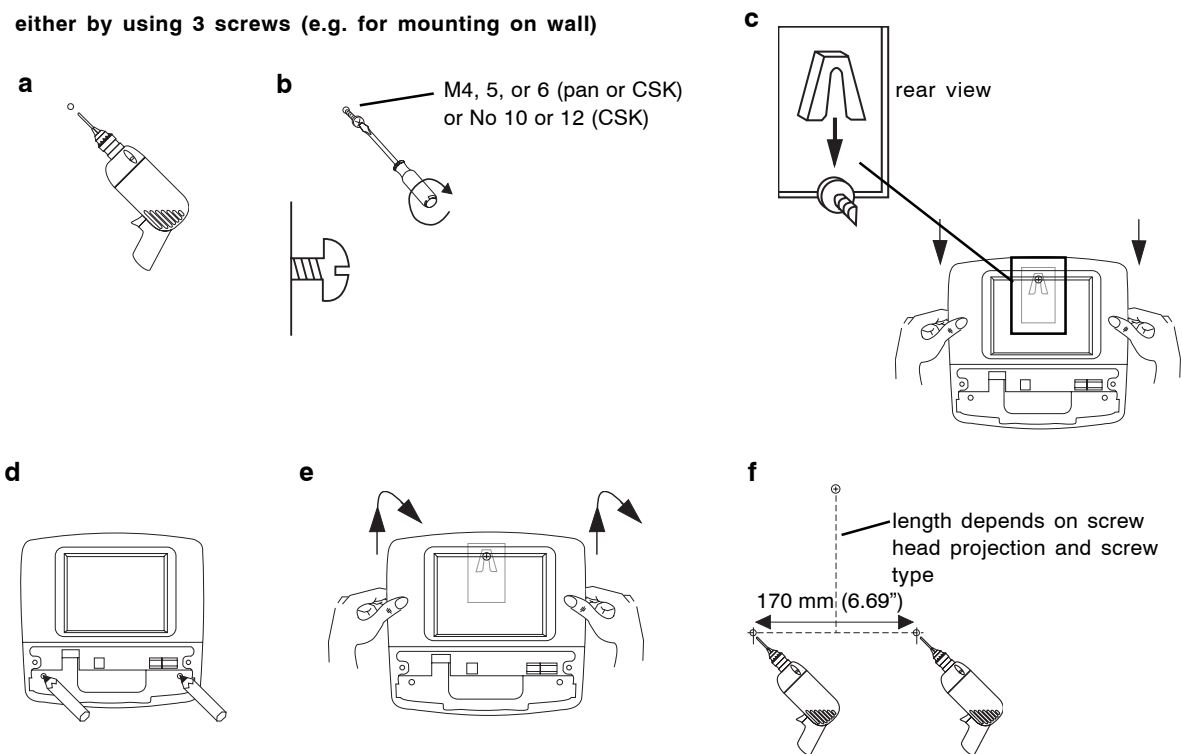

1.3 Installation - Mounting (continued)

**5** Mount Unit (continued)

either by using 3 screws (continued)

**g** cut rear cable entry hole if required

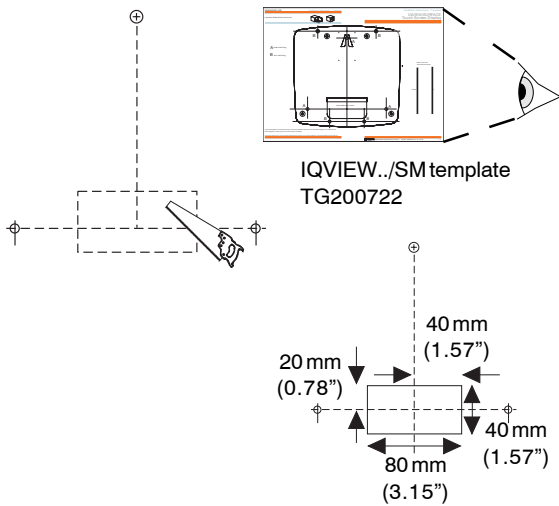

**h**

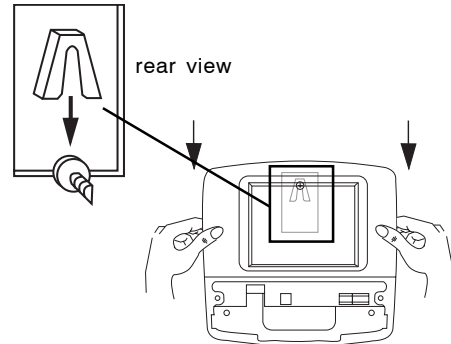

**i**

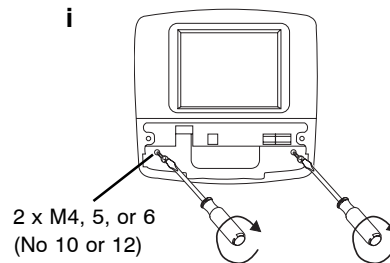

or by using 4 screws (e.g. mounting on a panel)

**a**

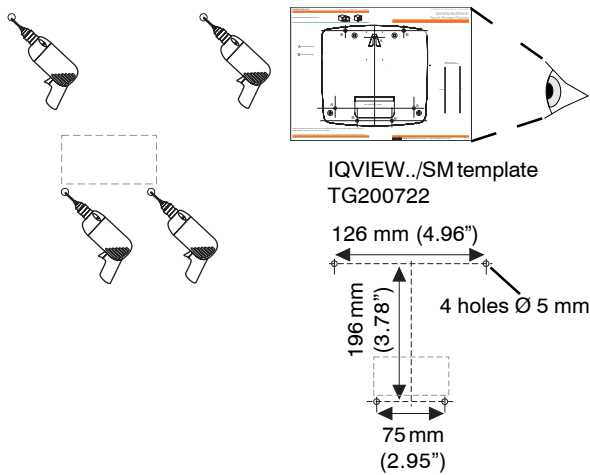

**b** cut rear cable entry hole if required

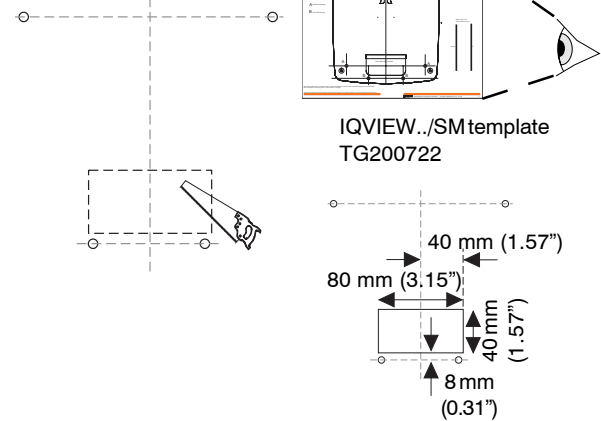

**c**

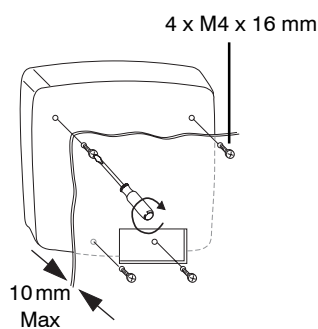

1.3 Installation - Mounting (continued)

**6** Route Cables  
rear entry

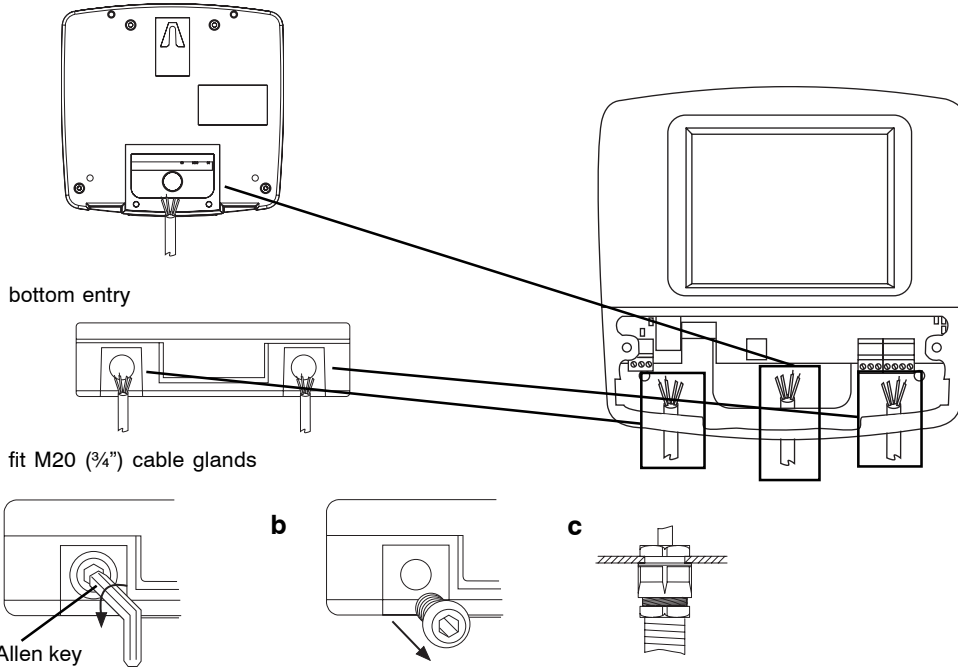

**7** Connect Power

28 to 36 Vdc or 24 Vac ±10 %, 50/60 Hz  
 IQView consumption <= 24 VA maximum (13 VA typical).  
 The IQView consumes 13 VA, but the input power supply should be capable of 24 VA to cater for startup current

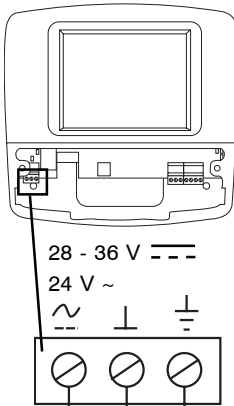

**WARNING:** This apparatus must be earthed (grounded) (through input power supply earth (ground) terminal)

**WARNING**  
 Do not attempt to supply power through the RS232 connector (as is done with NDP). This will damage the unit.

**DO NOT SWITCH ON**

terminal size 0.5 to 2.5 mm<sup>2</sup> (14 to 20 AWG)

~ 24 Vac 24 Vac E  
 --- 28 Vdc +28V 0V E

using 28 Vdc power supply (e.g. PSR/230/24-2.5)

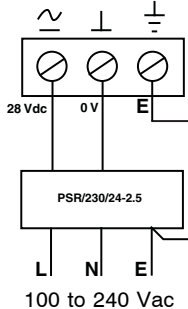

using 230V/24V ac transformer with isolated output (e.g. ACC/24VAC)

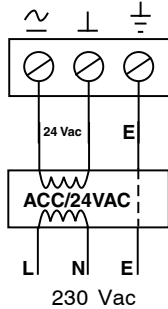

using 230V/24V ac transformer with one side earthed (grounded)

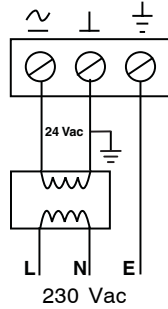

**8** Configure

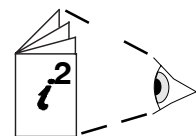

IQView../SM Installation Instructions - Sheet 2

## IQView../SM Surface Mount Touch Screen Display

### SHEET 2: Installation Instructions

#### 2.1 Installation - Mounting (continued)

**9 Mount Unit**

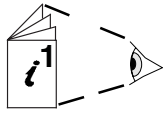

IQVIEW../SM  
Installation Instructions -  
Sheet 1

**10 Connect RS232**  
only connection for **IQView Mono**,  
if required for **IQView** (standard version)

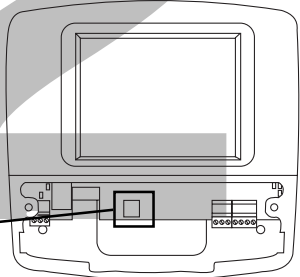

IQ3, IQ2xx, (some IQ1xx with RJ11)

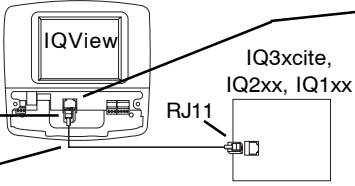

RJ11 CABLE/EJ105650  
(supplied with IQView Mono, not IQView standard version)

**WARNING**  
Do not attempt to supply power through the RS232 connector (as is done with NDP). This will damage the unit.

IQ1xx or CNC with 25 Way D type female

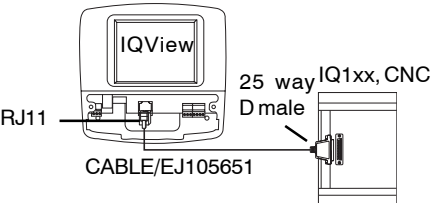

RJ11 CABLE/EJ105651  
25 way D male IQ1xx, CNC

IQ1xx with 5 in line plug

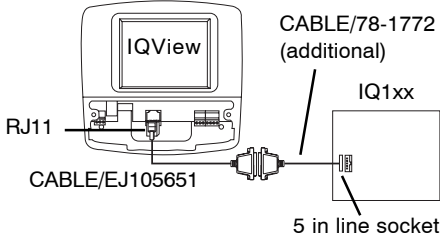

RJ11 CABLE/EJ105651 CABLE/78-1772 (additional)  
5 in line socket IQ1xx

---

**11 Connect Ethernet**  **IQView (standard version) only**  
if required, and if not connected to RS232 as in step 10

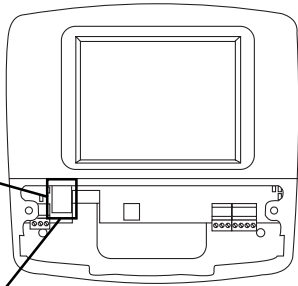

**either connect to an Ethernet hub**  
use standard Ethernet cable

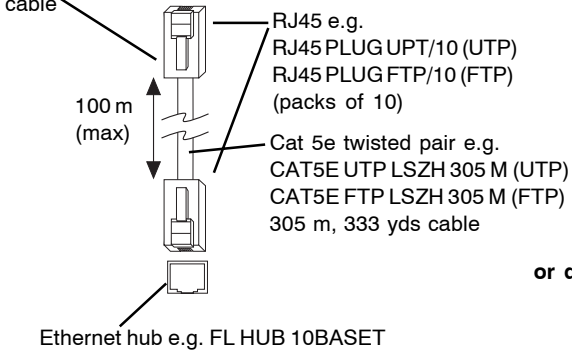

100 m (max)

RJ45 e.g.  
RJ45 PLUG UPT/10 (UTP)  
RJ45 PLUG FTP/10 (FTP)  
(packs of 10)

Cat 5e twisted pair e.g.  
CAT5E UTP LSZH 305 M (UTP)  
CAT5E FTP LSZH 305 M (FTP)  
305 m, 333 yds cable

Ethernet hub e.g. FL HUB 10BASET

**or direct connect to an IQ3 or EINC**

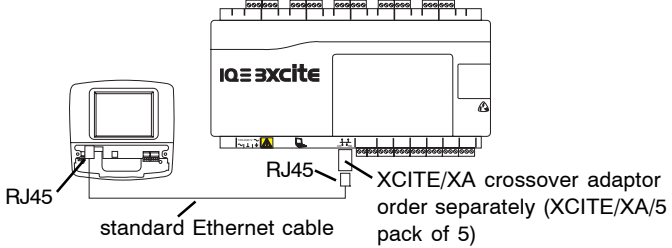

RJ45 standard Ethernet cable  
RJ45 XCITE/XA crossover adaptor  
order separately (XCITE/XA/5 pack of 5)

2.1 Installation - Mounting (continued)

12

**Connect Current Loop**  IQView (standard version) only

if required and if not connected to RS232 as in step 10 or to Ethernet as in step 11

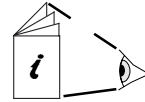

Network Engineering Manual, 92-1735

Cable	1k2 baud	4k8 baud	9k6 baud	19k2 baud	No. of Wires
Belden 9182	1000 m (1090 yds)	1000 m (1090 yds)	1000 m (1090 yds)	700 m (765 yds)	2
Belden 9207	1000 m (1090 yds)	1000 m (1090 yds)	1000 m (1090 yds)	500 m (545 yds)	2
Trend TP/1/1/22/HF/200 (Belden 8761)	1000 m (1090 yds)	1000 m (1090 yds)	700 m (765 yds)	350 m (380 yds)	2
Trend TP/2/2/22/HF/200 (Belden 8723)	1000 m (1090 yds)	1000 m (1090 yds)	500 m (545 yds)	250 m (270 yds)	4

polarity independent  
terminal size 0.5 to 2.5 mm<sup>2</sup> (14 to 20 AWG)

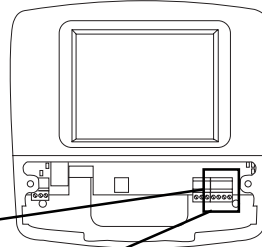

4 wire

2 wire

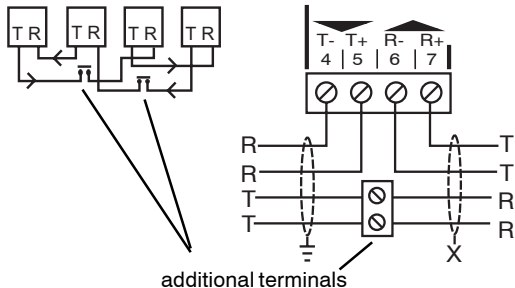

additional terminals

13

**Connect Relay Output** if required (for alarm notification)

AC rating: 62.5 VA e.g. 40 Vac max @ 1.5 A, 24 Vac @ 2.5 A  
DC rating: 60 W e.g. 40 Vdc max @ 1.5 A, 24 Vdc @ 2.5 A  
*Note that UL rating applies up to 30V maximum*

*Note that the relay output alarm action must be enabled (it is enabled by default), see 2.2 step 15.*

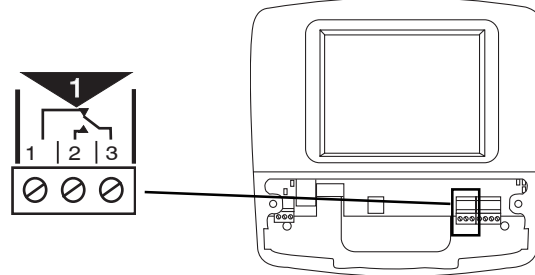
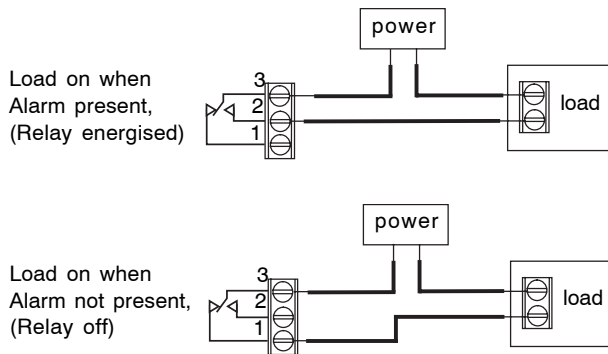

**WARNING:**  The wires may be connected to hazardous voltages. Disconnect power before attempting any wiring.

 **Arc suppression recommended**  
Relay Output Arc Suppression Installation Instructions TG200208

14

**Replace Covers**

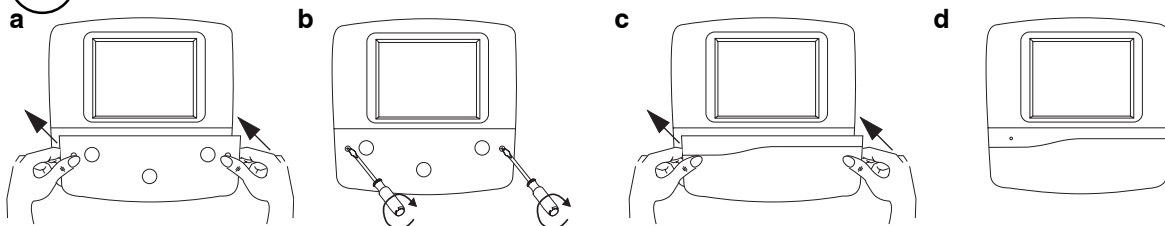

2.2 Installation - Configuration

**1 Read Licence**

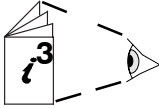

Read and agree to End User Licence Agreement (these instructions Sheet 3 Section 2)

**2 Switch On**

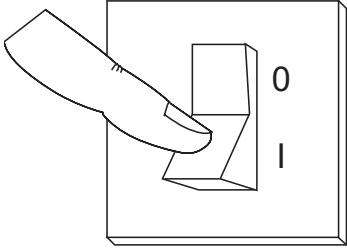

**3 Check Power LED**

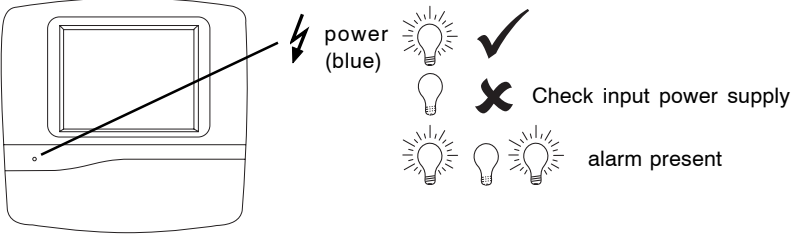

power (blue)

Check input power supply

alarm present

**4 Specify Site Connection**

(a) Enter 'Site Name'

*Note that for IQView Mono, the RS232 connection will be selected, all other selections will not be available, and the user should jump to stage (d) below to 'Connect to CNC'/'RS232' and enter the baud rate.*

(b) Select first connection stage:  
 either **'Connect to CNC'** - If connecting to either Ethernet vCNC (vCNC in EINC or IQ3) or RS232 (CNC module or IQ controller's local supervisor port)  
 or **'Connect as Device'** - If IQView is device on current loop Lan (using IQView's internal CNC), or device on Ethernet Lan (using IQView's internal vCNC)

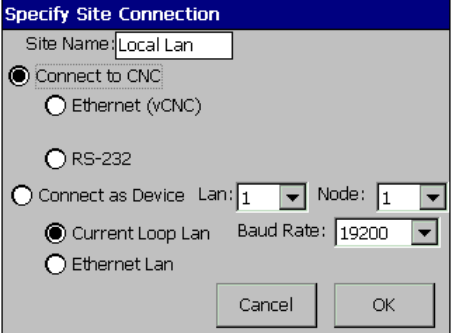

(c) Select second connection stage:  
 If 'Connect to CNC' was selected  
 either **'Ethernet (vCNC)'** - If connecting to vCNC in EINC or IQ3  
 or **'RS232'** - If connecting to CNC module, or IQ controller's local supervisor CNC (sCNC)  
 If 'Connect as Device' was selected  
 either **'Current Loop Lan'** - If connecting IQView as device on a current loop Lan (using IQView's internal CNC)  
 or **'Ethernet Lan'** - If connecting IQView as device on Ethernet Lan (using IQView's internal vCNC)

(d) Setup up communication parameters  
 If 'Connect to CNC'/'Ethernet (vCNC)' - Set IP address (or host name) of IQ3 or EINC and port number of the vCNC  
 If 'Connect to CNC'/'RS232' - Set baud rate for communication between IQView and CNC or IQ controller's local supervisor port to match the baud rate set in the remote device (controller local supervisor port baud rate is normally 9600 baud)  
 If 'Connect as Device'/'Current Loop Lan' - Set up IQView's Lan number (to be unique on internetwork and to match other devices on Lan), network address (to be unique on Lan), and baud rate (to be same as other nodes on Lan)  
 If 'Connect as Device'/'Ethernet Lan' - Set up IQView's Lan number (to be unique on internetwork and to match other devices on Lan) and network address (to be unique on Lan). Set up UDP port to match address used by rest of IQ system

(e) The IQView will now attempt to find its own Lan number (from an INC). If successful it will try to learn the internetwork and display all the associated Lan icons including local Lan, if unsuccessful it will just display its own Lan icon (with Lan number 0).  
 If either **Ethernet (vCNC)**, or **Ethernet Lan** have been selected, the default is for the Ethernet IP address details to be automatically set up. If DHCP server is operating it will set up the IP address details, if not the details will be set up by auto-negotiation with the other devices on the Ethernet Lan.  
 For Ethernet connections proceed with step 5 and for all other connections go to step 6.

2.2 Installation - Configuration (continued)

**5 Set up IQView's Ethernet Settings** IQView (standard version) only

if either 'Connect to CNC'/'Ethernet vCNC', or 'Connect as Device'/'Ethernet Lan' set up as above.

Note that if auto IP addressing is required (as per default) go to (d)

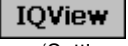

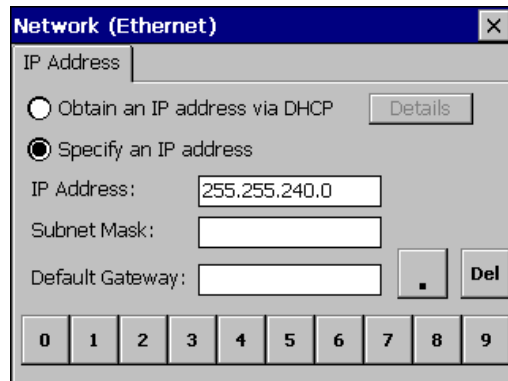
- (a) Tap on IQView menu icon  in the menu rail on the top of the screen, and tap on 'Settings/Network (Ethernet)'.
- (b) Change IP address source:  
from 'Obtain IP address via DHCP' (default)  
IP settings being set up automatically  
to 'Specify an IP address'  
IP settings being set up manually
- (c) Enter IP Address  
Subnet Mask  
Default Gateway - router IP address (if communications cross router)  
Select servers tab and enter  
WINS Server IP Address(es) (if host names being used across router)



Note that the these details can be set up using IPTool (v1.1 or greater) rather than tapping them in on the screen  
Go to (e)

- (d) If 'Obtain IP address via DHCP' selected, and there is no DHCP server on the segment, then enter  
Default Gateway - router IP address (if communications cross router)  
Select servers tab and enter  
WINS Server IP Address(es) (if host names being used across router)

Note that the these details can be set up using IPTool (v1.1 or greater) rather than tapping them in on the screen

- (e) Tap  to close the box, and the unit will reset.
- (f) If network is to cross router enter remote devices' IP addresses (or host names) and subnet masks using IPTool
- (g) Re - initialise the site connection by selecting  and 'Relnit Connection'.  
The IQView will now attempt to find its own Lan number (from an INC). If successful it will try to learn the internetwork, if unsuccessful it will just display its own Lan icon.



Note that the time taken for the system to be available for mapping will depend on the type of Ethernet connection. If connecting to 'Connect to CNC', 'Ethernet vCNC' it can be instantaneous (if the rest of the system is setup). If connecting 'Connect as Device', 'Ethernet Lan' it can take from <30s to <130s depending on its IP address and whether the network crosses a router.

**6 Learn Entire Site**

- (a) The IQView will display the adjacent dialogue box. Recommend select 'Yes' to learn of all controllers. The box times out after 5 s and will learn the all controllers by default. (Selecting 'No' means that the controllers should be learnt later when user selects the learn site/Lan functions).

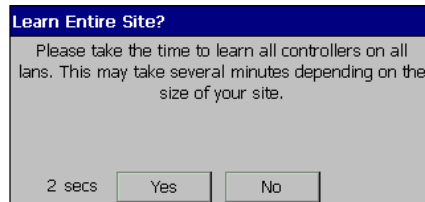

**7 Configure**

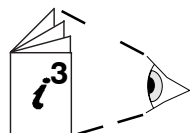

IQVIEW../SM Installation  
Instructions - Sheet 3

## IQView../SM Surface Mount Touch Screen Display

### SHEET 3: Installation Instructions

#### 3.1 Installation - Configuration (continued)

**8 Mount Unit**

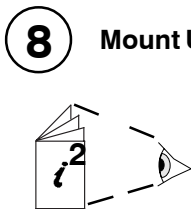



IQVIEW../SM  
Installation Instructions -  
Sheet 2

**9 Check Connection**

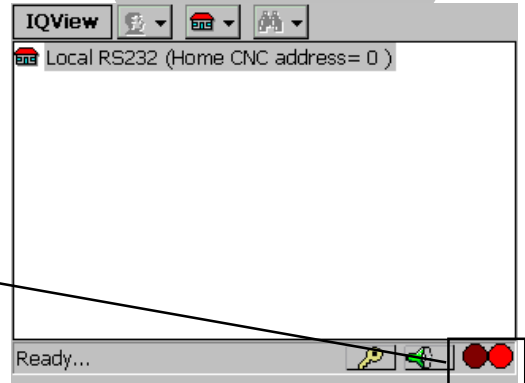
A failure to connect in steps 4, 5, or 6 will produce a dialogue box detailing the reason for failure.



The connection can be checked at any time by tapping on the comms icons in the bottom right corner of the display.

-  (green flicker) Icons have been tapped and the check is in progress
-  (green steady) Communications OK
-  (red steady) Communications fail

**10 Remove Covers**

if 'Connect to CNC'/'Ethernet (vCNC)', 'Connect as Device'/'Ethernet Lan', or 'Connect as Device'/'Current Loop Lan'

**a**

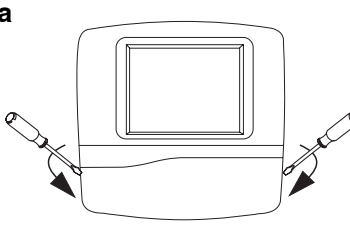

**b**

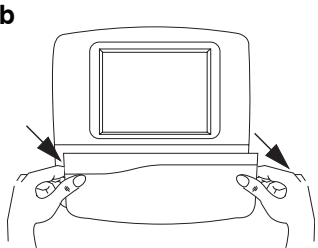

**c**

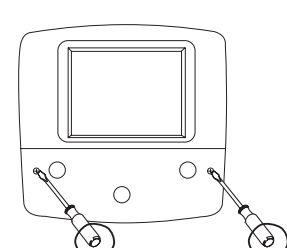

**d**

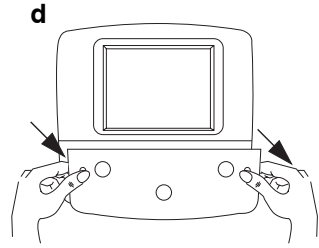

**e**

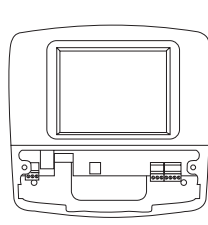

**11 Check Ethernet OK LED** 

if 'Connect to CNC'/'Ethernet (vCNC)' or 'Connect as Device'/'Ethernet Lan'

Ethernet OK  
(green)





Check Ethernet Connection and/or vCNC

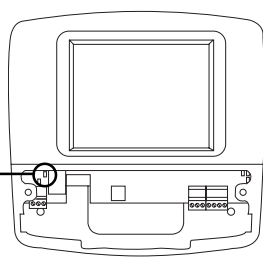

3.1 Installation - Configuration (continued)

**12 Check Current Loop Lan LEDs**  if 'Connect as Device'/'Current Loop Lan'

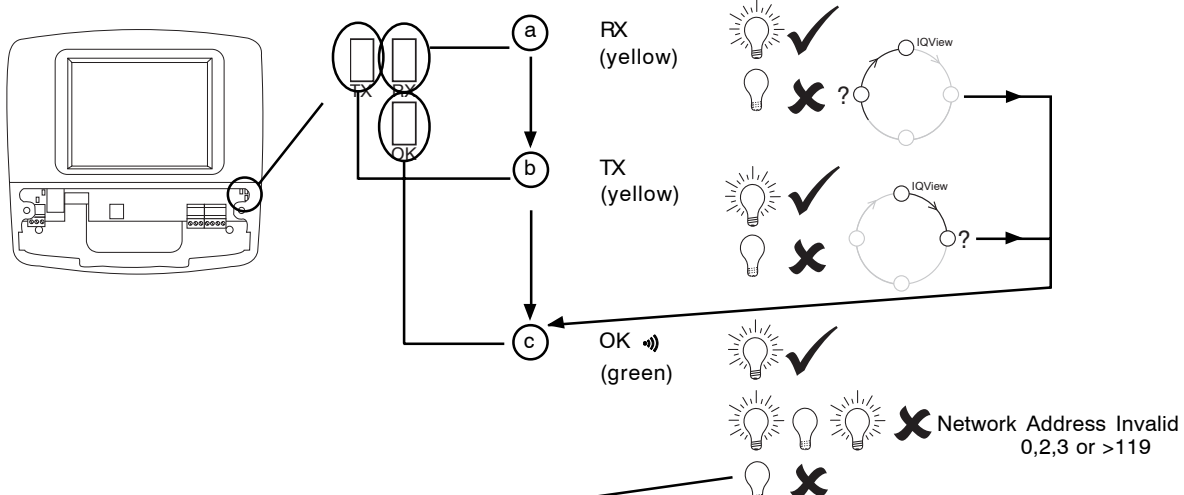

LED Label	Color	Indicator	Network Address Range
RX	yellow	Light on (✓)	0, 2, 3 or >119
RX	yellow	Light off (✗)	0, 2, 3 or >119
TX	yellow	Light on (✓)	0, 2, 3 or >119
TX	yellow	Light off (✗)	0, 2, 3 or >119
OK	green	Light on (✓)	0, 2, 3 or >119
OK	green	Light off (✗)	0, 2, 3 or >119

**OK (✓)** Check network cabling for short circuits with a multimeter (NOT Megger)

**Light on (✓)** Check baud rate. Power up other nodes until faulty node is found (OK (✓) (Light)). Correct fault.

**Light off (✗)** IQView Faulty

**Light on (✓)** IQView Faulty

**13 Replace Covers** if appropriate

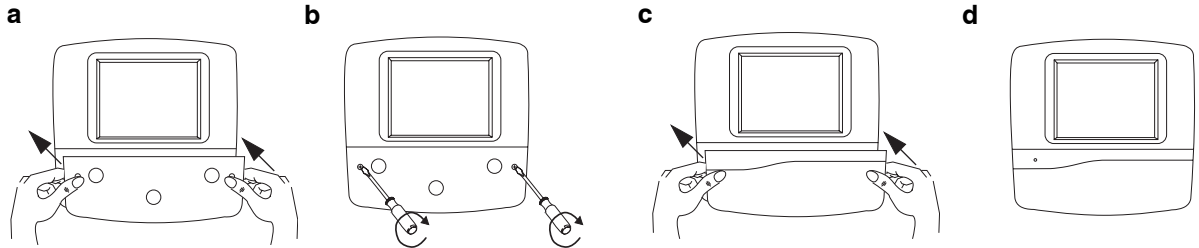

a: Lifting the front cover off the device.

b: Removing the screws that hold the cover in place.

c: Realigning the front cover with the device.

d: The front cover is fully attached to the device.

**14 Test System**

(a) Tap on controller icon in navigator e.g.  (IQ2 controller)

(b) Tap on controller menu icon e.g. 

(c) Tap on 'Modules'/'Sensors' on drop down menus

(d) Check sensors display

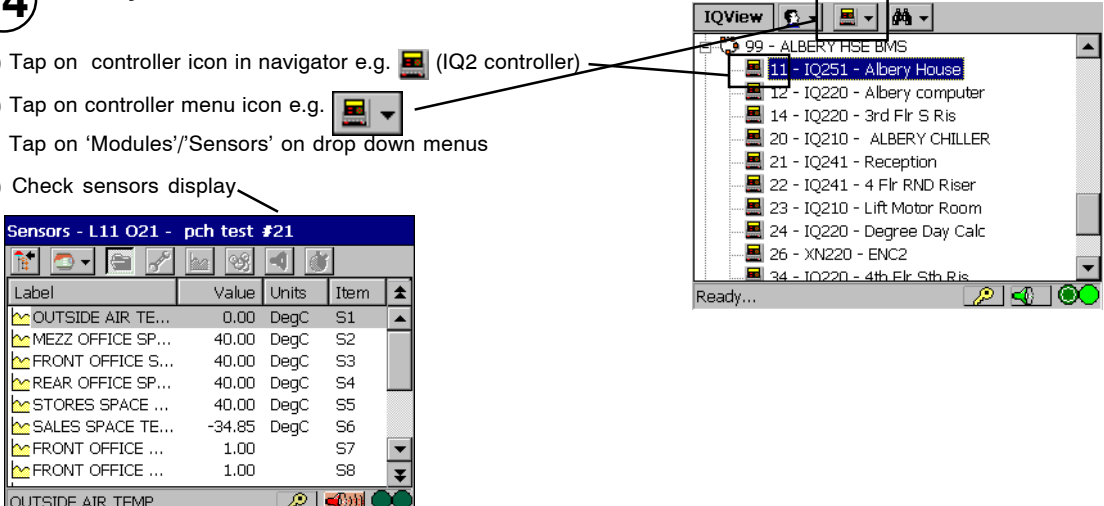

Label	Value	Units	Item
OUTSIDE AIR TE...	0.00	DegC	S1
MEZZ OFFICE SP...	40.00	DegC	S2
FRONT OFFICE S...	40.00	DegC	S3
REAR OFFICE SP...	40.00	DegC	S4
STORES SPACE ...	40.00	DegC	S5
SALES SPACE TE...	-34.85	DegC	S6
FRONT OFFICE ...	1.00		S7
FRONT OFFICE ...	1.00		S8

3.1 Installation - Configuration (continued)

**15 Test Relay Output** if required

(a) Tap **IQView** in the menu rail on top of the screen and tap on 'Settings'/Alarms'

(b) Tap on the relay action (to select relay action)

(c) Tap to close the box

(d) Tap in bottom rail of screen

(e) Tap and choose 'Turn alarm on' from drop down menu

(f) Listen for relay to click and check relay operates the connected device

(g) Tap in bottom rail of screen to stop alarm test.

**Alarm Settings**

In the list, check the alarm categories for which alarms will be displayed. For all selected categories, choose the alarm action(s)

Critical     Module     Dialler     Unknown  
 General     Network     Access

---

Choose the alarm action(s)     Sound Buzzer

Flash LED     Flash Screen     Relay

**Network Alarms = 6 (Current=5, Acked=6)**

Time Received	Source	Alarm Datafield	
18/08 01:00	L000	Local LAN	Re...
18/08 00:54	L000	Local LAN	Re...
15/08 22:47	L59012	G001HELP2247	
15/08 18:58	L40053	G501HELP1858	
15/08 18:59	L40016	G000HELP1859	
15/08 03:51	L40052	G401HELP 351	

**16 Configure IQView** if required

IQView Manual TE200719

The following facilities may be configured by tapping **IQView** and selecting the facility from the drop down menu.

Facility	Defaults	Change if	Items
Users	Security disabled	Security required	Enable users and Guest and Admin users (already set up to defaults). More users can be added. Each user has a username, password, PIN, timeout, and a definition of what can be accessed or changed.
Alarm handling	All alarms accepted. Buzzer and LED alarm actions enabled; flash screen and relay disabled	Only some alarms are required, or alarm actions are to be changed	The types of alarms added to the received alarm display can be selected from critical, general, module, network, dialler, access, or unknown. The alarm actions (buzzer, flash LED, flash screen, and relay) can be individually enabled/disabled.
Time	Start from undefined date on power up and count up	If time and date required. Used for time/date stamping alarm acknowledgments, and for synchronising controllers (if required)	IQView's time and date
Display	Back light timeout set to 600s. Tap screen sound disabled	If back light timeout to be changed or tap screen sound to be enabled. Contrast can be adjusted to suit environment/viewing angle. Recalibrate screen if screen taps select wrong functions	Backlight Timeout, Tap screen sound on/off, Contrast adjust, Screen calibration
Language	English (UK) screens and formats	If different language required	Currently translates screen displays and changes date, time, and decimal separator formats (languages include English (UK), English (US), German, French, Danish, Norwegian, Spanish, and Swedish).

3.2 Disposal

**WEEE Directive :**

At the end of their useful life the packaging and product should be disposed of by a suitable recycling centre.

Do not dispose of with normal household waste.  
Do not burn.

### 3.3 End User Licence Agreement

#### EULA Terms

- You have acquired an IQView ("Device") that includes software licensed by Trend Control Systems Ltd from one or more software licensors ("Trend Control Systems Ltd Software Suppliers"). Such software products, as well as associated media printed materials and "online" or electronic documentation ("SOFTWARE") are protected by international intellectual property laws and treaties. The SOFTWARE is licensed, not sold. All rights reserved."
- IF YOU DO NOT AGREE TO THIS END USER LICENSE AGREEMENT ("EULA"), DO NOT USE THE DEVICE OR COPY THE SOFTWARE. INSTEAD, PROMPTLY CONTACT Trend Control Systems Ltd FOR INSTRUCTIONS ON RETURN OF THE UNUSED DEVICE(S) FOR A REFUND. **ANY USE OF THE SOFTWARE INCLUDING BUT NOT LIMITED TO USE ON THE DEVICE will constitute your agreement to the EULA (or Ratification of any previous consent).**
- **GRANT OF SOFTWARE LICENSE.** This EULA grants you the following license:
  - You may use the SOFTWARE only on the DEVICE
  - **NOT FAULT TOLERANT.** THE SOFTWARE IS NOT FAULT TOLERANT. TREND CONTROL SYSTEMS LTD HAS INDEPENDENTLY DETERMINED HOW TO USE THE SOFTWARE IN THE DEVICE, AND TREND CONTROL SYSTEMS LTD'S SOFTWARE SUPPLIERS HAS RELIED UPON TREND CONTROL SYSTEMS LTD TO CONDUCT SUFFICIENT TESTING TO DETERMINE THAT THE SOFTWARE IS SUITABLE FOR SUCH USE.
  - **NO WARRANTIES FOR THE SOFTWARE. THE SOFTWARE is provided "AS IS" and with all faults. THE ENTIRE RISK AS TO SATISFACTORY QUALITY, PERFORMANCE, ACCURACY, AND EFFORT (INCLUDING LACK OF NEGLIGENCE) IS WITH YOU. ALSO, THERE IS NO WARRANTY AGAINST INTERFERENCE WITH YOUR ENJOYMENT OF THE SOFTWARE OR AGAINST INFRINGEMENT.** IF YOU HAVE RECEIVED ANY WARRANTIES REGARDING THE DEVICE OR THE SOFTWARE, THOSE WARRANTIES DO NOT ORIGINATE FROM, AND ARE NOT BINDING ON, TREND CONTROL SYSTEMS LTD'S SOFTWARE SUPPLIERS.
  - **Note on Java Support.** The SOFTWARE may contain support for programs written in Java. Java technology is not fault tolerant and is not designed, manufactured, or intended for use or resale as online control equipment in hazardous environments requiring fail-safe performance, such as in the operation of nuclear facilities, aircraft navigation or communication systems, air traffic control, direct life support machines, or weapons systems, in which the failure of Java technology could lead directly to death, personal injury, or severe physical or environmental damage. Sun Microsystems, Inc. has contractually obligated Trend Control Systems Ltd's software suppliers to make this disclaimer.
  - **No Liability for Certain Damages. EXCEPT AS PROHIBITED BY LAW, TREND CONTROL SYSTEMS LTD'S SOFTWARE SUPPLIERS SHALL HAVE NO LIABILITY FOR ANY INDIRECT, SPECIAL, CONSEQUENTIAL OR INCIDENTAL DAMAGES ARISING FROM OR IN CONNECTION WITH THE USE OR PERFORMANCE OF THE SOFTWARE. THIS LIMITATION SHALL APPLY EVEN IF ANY REMEDY FAILS OF ITS ESSENTIAL PURPOSE. IN NO EVENT SHALL TREND CONTROL SYSTEMS LTD'S SOFTWARE SUPPLIERS BE LIABLE FOR ANY AMOUNT IN EXCESS OF U.S. TWO HUNDRED FIFTY DOLLARS (U.S.\$250.00).**
  - **Limitations on Reverse Engineering, Decompilation, and Disassembly.** You may not reverse engineer, decompile, or disassemble the SOFTWARE, except and only to the extent that such activity is expressly permitted by applicable law notwithstanding this limitation.
  - **SOFTWARE TRANSFER ALLOWED BUT WITH RESTRICTIONS.** You may permanently transfer rights under this EULA only as part of a permanent sale or transfer of the Device, and only if the recipient agrees to this EULA. If the SOFTWARE is an upgrade, any transfer must also include all prior versions of the SOFTWARE.
  - **No Liability for Certain Damages. EXCEPT AS PROHIBITED BY LAW, TREND CONTROL SYSTEMS LTD'S SOFTWARE SUPPLIERS SHALL HAVE NO LIABILITY FOR ANY INDIRECT, SPECIAL, CONSEQUENTIAL OR INCIDENTAL DAMAGES ARISING FROM OR IN CONNECTION WITH THE USE OR PERFORMANCE OF THE SOFTWARE. THIS LIMITATION SHALL APPLY EVEN IF ANY REMEDY FAILS OF ITS ESSENTIAL PURPOSE. IN NO EVENT SHALL TREND CONTROL SYSTEMS LTD'S SOFTWARE SUPPLIERS BE LIABLE FOR ANY AMOUNT IN EXCESS OF U.S. TWO HUNDRED FIFTY DOLLARS (U.S.\$250.00).**
  - **Limitations on Reverse Engineering, Decompilation, and Disassembly.** You may not reverse engineer, decompile, or disassemble the SOFTWARE, except and only to the extent that such activity is expressly permitted by applicable law notwithstanding this limitation.
  - **SOFTWARE TRANSFER ALLOWED BUT WITH RESTRICTIONS.** You may permanently transfer rights under this EULA only as part of a permanent sale or transfer of the Device, and only if the recipient agrees to this EULA. If the SOFTWARE is an upgrade, any transfer must also include all prior versions of the SOFTWARE.

Manufactured for and on behalf of the Environmental and Combustion Controls Division of Honeywell Technologies Sàrl, Ecublens, Route du Bois 37, Switzerland by its Authorized Representative, Trend Control Systems Limited.

Trend Control Systems Limited reserves the right to revise this publication from time to time and make changes to the content hereof without obligation to notify any person of such revisions or changes.

#### Trend Control Systems Limited

P.O. Box 34, Horsham, West Sussex, RH12 2YF, UK. Tel:+44 (0)1403 211888 Fax:+44 (0)1403 241608 www.trend-controls.com

#### Trend Control Systems USA

6670 185th Avenue NE, Redmond, Washington 98052, USA. Tel: (425)869-8400, Fax: (425)869-8445 www.trend-controls.com