

Spring return actuator with emergency function for adjusting air dampers in ventilation and air conditioning systems in buildings

- For air dampers up to approx. 2 m²
- Torque 10 Nm
- Nominal voltage AC 230 V
- Control: Open-close
- Two integrated auxiliary switches

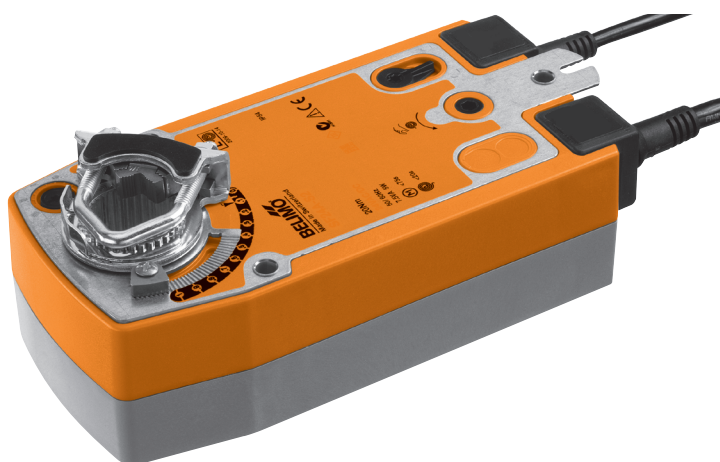

Technical data

Electrical data	Nominal voltage	AC 230 V, 50/60 Hz
	Nominal voltage range	AC 195 ... 264 V
	Power consumption	In operation 6 W @ nominal torque At rest 2.5 W For wire sizing 9.5 VA
	Auxiliary switch	2 x SPDT, 1 mA ... 3 (0.5) A, AC 250 V <input type="checkbox"/> (1 x fix 10% / 1 x adjustable 10 ... 90%)
Functional data	Connection Motor	Cable 1 m, 2 x 0.75 mm ²
	Auxiliary switch	Cable 1 m, 6 x 0.75 mm ²
	Torque Motor	Min. 10 Nm @ nominal voltage
	Spring return	Min. 10 Nm
	Direction of rotation	Can be selected by mounting L / R
	Manual override	With hand crank and interlocking switch
	Angle of rotation	Max. 95°↔, can be limited with adjustable mechanical end stop
	Running time Motor	≤75 s (0 ... 10 Nm)
	Spring return	≤20 s @ -20 ... 50°C / max. 60 s @ -30°C
	Sound power level Motor	≤45 dB (A)
Spring return	≤62 dB (A)	
Service life	Min. 60,000 emergency positions	
Position indication	Mechanical	
Safety	Protection class	II Totally insulated <input type="checkbox"/>
	Protection mode	IP54 NEMA2, UL Enclosure Type 2
	EMC	CE according to 2004/108/EC
	Low-voltage directive	CE according to 2006/95/EC
	Certification	cULus according to UL 60730-1A and UL 60730-2-14 and CAN/CSA E60730-1:02 Certified to IEC/EN 60730-1 and IEC/EN 60730-2-14
	Mode of operation	Type 1.AA.B
	Rated impulse voltage Actuator	4 kV
	Auxiliary switch	2.5 kV
	Control pollution degree	3
	Ambient temperature	-30 ... +50°C
Non-operating temperature	-40 ... +80°C	
Ambient humidity	95% r.h., non-condensating	
Maintenance	Maintenance-free	
Dimensions / Weight	Dimensions	See «Dimensions» on page 3
	Weight	Approx. 2.0 kg

Safety notes



- The actuator is not allowed to be used outside the specified field of application, especially in aircraft or in any other airborne means of transport.
- **Caution: Power supply voltage!**
- It may only be installed by suitably trained personnel. Any legal regulations or regulations issued by authorities must be observed during assembly.
- The device may only be opened at the manufacturer's site. It does not contain any parts that can be replaced or repaired by the user.
- The cable must not be removed from the device.
- When calculating the required torque, the specifications supplied by the damper manufacturers (cross-section, design, installation site), and the air flow conditions must be observed.
- The device contains electrical and electronic components and is not allowed to be disposed of as household refuse. All locally valid regulations and requirements must be observed.

Product features

Mode of operation	The actuator moves the damper to the operating position at the same time as tensioning the return spring. The damper is turned back to the emergency position by spring force if the supply voltage is interrupted.
Simple direct mounting	Simple direct mounting on the damper spindle with a universal spindle clamp, supplied with an anti-rotation strap to prevent the actuator from rotating.
Manual override	Manual operation of the damper with the hand crank, locking in any position with the interlocking switch. Unlocking is manual or automatic by applying the operating voltage.
Adjustable angle of rotation	Adjustable angle of rotation with mechanical end stop.
High operational reliability	The actuator is overload-proof, requires no limit switches and automatically stops when the end stop is reached.
Flexible signalization	The actuator has one auxiliary switch with a fixed setting and one adjustable auxiliary switch. They permit a 10% or 10 ... 90% angle of rotation to be signalled.

Electrical installation

Wiring diagram

Notes

- Caution: Power supply voltage!
- Parallel connection of other actuators possible. Note the performance data.

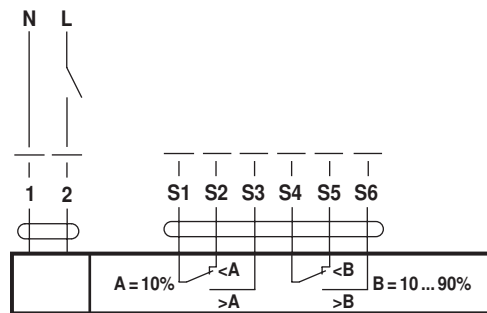

Cable colours:

- 1 = black
- 2 = red
- S1 = violet
- S2 = red
- S3 = white
- S4 = orange
- S5 = pink
- S6 = grey

Accessories

	<u>Description</u>
Electrical accessories	Auxiliary switch S2A-F
Mechanical accessories	Various accessories (clamps, shaft extensions etc.)

Dimensions [mm]

Dimensional drawings

Variant 1a:

3/4"-spindle clamp (with insertion part) EU Standard

Damper spindle	Length	● I	■ I	◆ I
	≥85	10...22	10	14...25.4
	≥15			

Variant 1b:

1"-spindle clamp (without insertion part) EU Standard

Damper spindle	Length	● I	■ I
	≥85	19...25.4 (26.7)	12...18
	≥15		

Variant 2:

1/2"-spindle clamp (optional via configuration)

Damper spindle	Length	● I	◆ I
	≥85	10...19	14...20
	≥15		

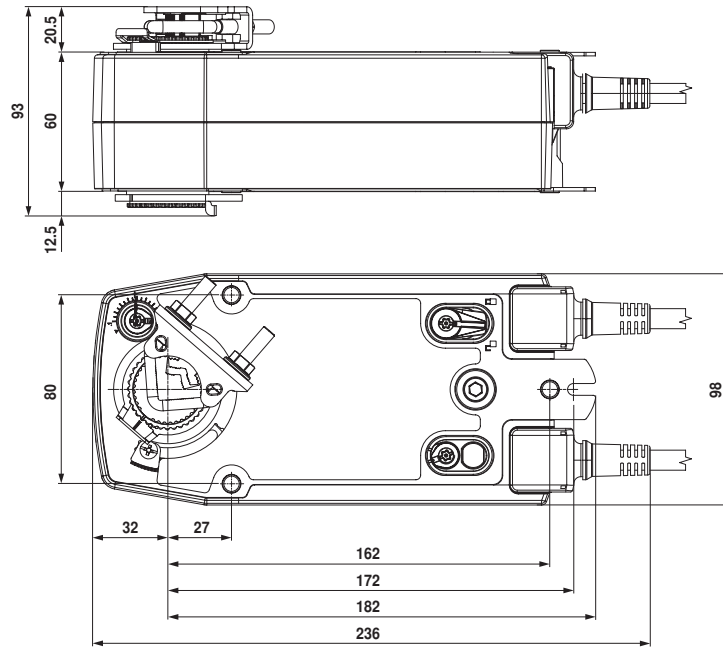

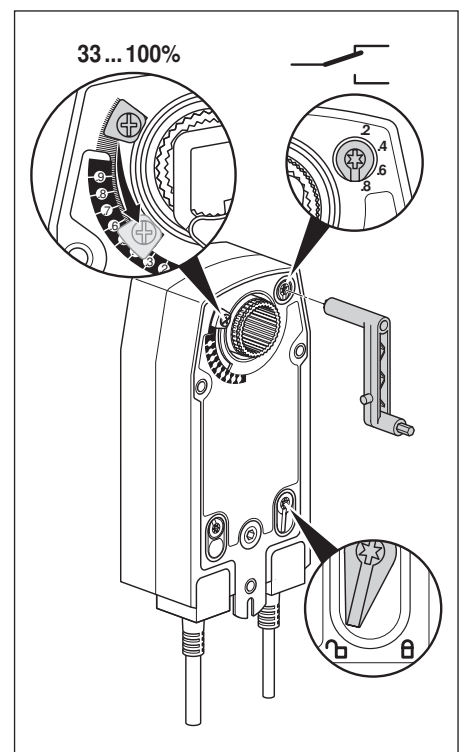
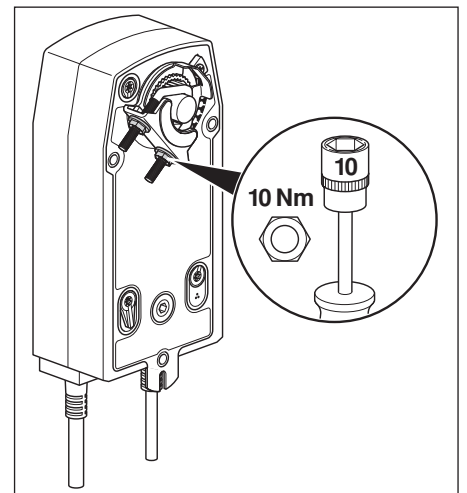
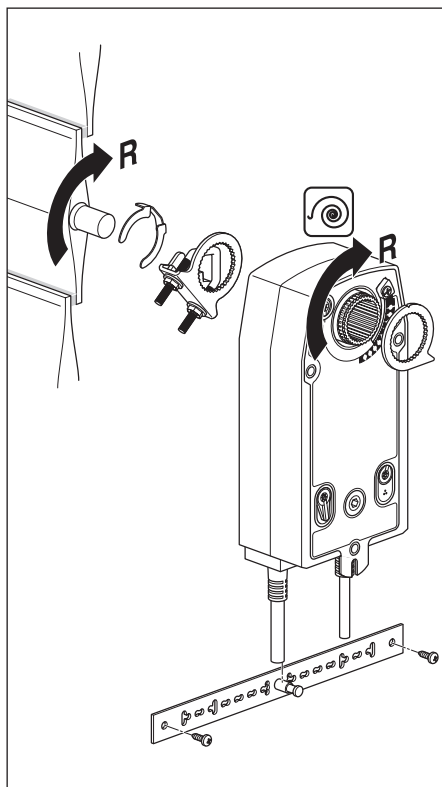
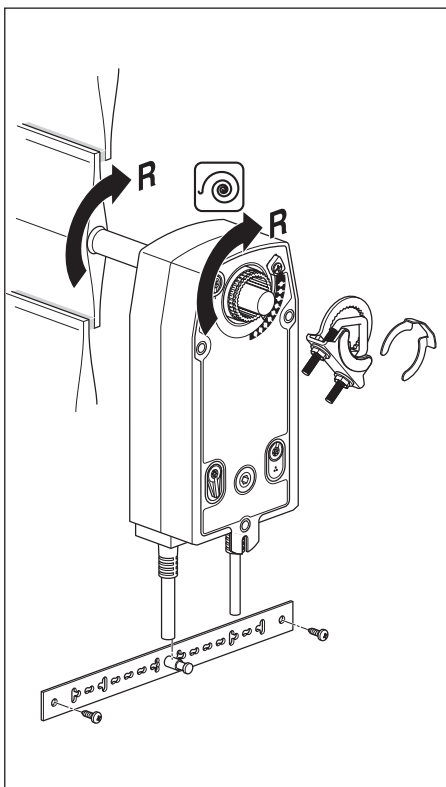
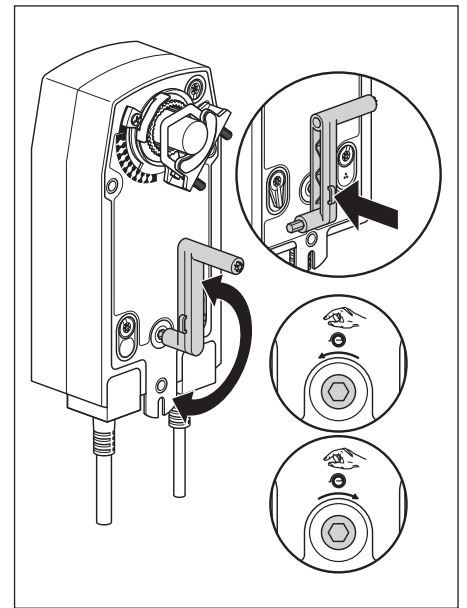
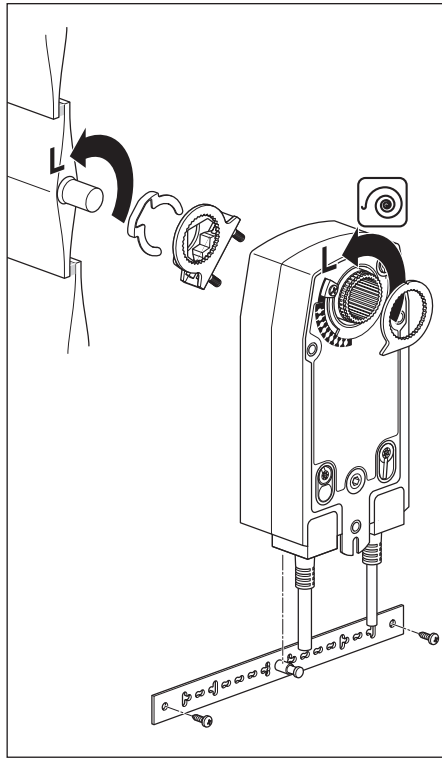
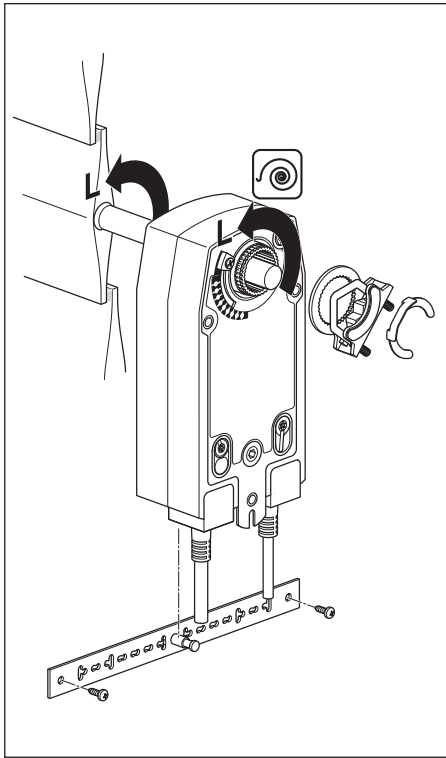
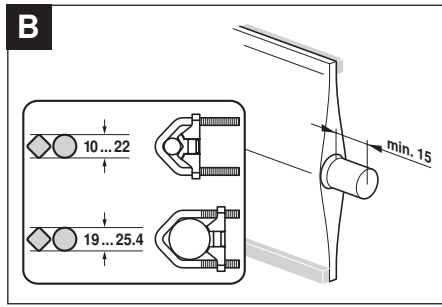
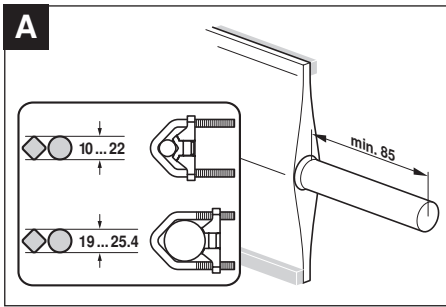

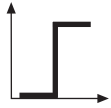

AC 24 V / DC 24 V

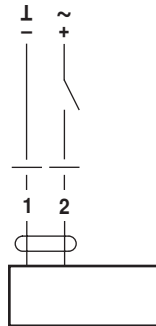

NF24A
SF24A

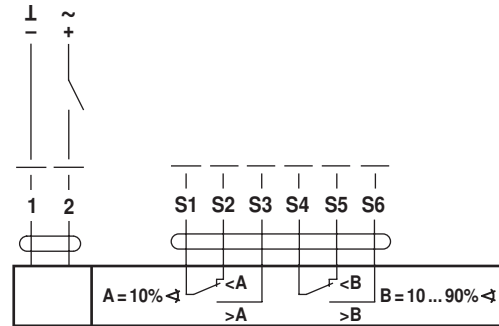

NF24A-S2
SF24A-S2

AC 100 ... 240 V ⚠

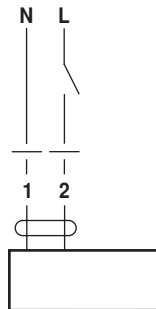

NF230A
SF230A

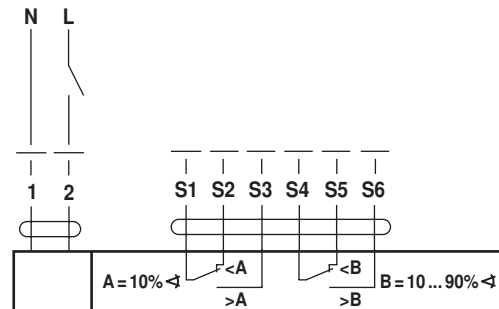

NF230A-S2
SF230A-S2